

RESPONSES AND VULNERABILITY OF COMPOSITE RAILWAY TRACK SLAB TO TRAIN DERAILMENTS

*Sakdirat Kaewunruen¹, Olivia Mirza² and Daniel Thomson³

¹School of Engineering, University of Birmingham, Edgbaston, B15 2TT UK

²School of Computing, Engineering and Mathematics, Western Sydney University, Kingswood NSW, 2577
Australia

³Engineering Services, Sydney Trains, Sydney NSW 2000 Australia

*s.kaewunruen@bham.ac.uk

ABSTRACT

Modern replacement of deteriorated timber transom sleepers by steel-concrete composite slabs can significantly improve asset management strategy for railway bridges over their life cycle. Track engineers can take advantage of steel-concrete composite technology over traditional concrete slabs. The design of such steel-composite track slabs has shown 10-20% reduction in the component depth and thus the weight. These benefits enable the composite slabs to fit brown-field maintenance project where merely aging transoms can be renewed and the new composite slabs can be installed over existing girders and support systems. In practice, railway bridge structure is designed to embrace redundancy assuring public safety. The risk and consequences of train derailment over the bridge has prompted railway authority to investigate the vulnerability of railway bridge system. Therefore, the design and modelling of this composite slab has been verified by previous work of the authors. This paper presents the dynamic responses and vulnerability of the composite track slabs to train derailments. A nonlinear finite element model of integrated train-track-bridge has been developed and validated using field data. The impact analysis has then been carried out using ABAQUS Explicit to evaluate the dynamic responses of the composite railway track slabs, benchmarked with quasi-static code-based design method. This study enhances the insight into the dynamic behaviour of vulnerable track slabs so that track engineers can predict the damage arisen from a train derailment.

Keywords: *Railway bridge; steel-concrete composite; transom; railway bridge sleeper; track slab, train derailment; failure analysis; dynamic finite elements*

1. Introduction

Over 90% of Australia's railway bridges are using timber transoms. Similar percentages of aged railway bridges in the UK and Europe have also utilised timber transoms (or commonly known as 'railway bridge sleepers'). At present, railway infrastructure managers require to renew around 3.5 million of aging and failing timber transoms around the world in order to upgrade the railway lines and to maintain existing rail lines. Griffin et al. [1-2] found that timber transoms are generally replaced within 10 to 20 years' period of time, resulting in a shorter turnover period and additional costs for track maintenance [3-4]. This research was undertaken to explore the replacement of timber transoms based on a case study for the iconic Sydney Harbour Bridge using new composite materials. Composite transoms are a good alternative to timber transoms due to the production of greenhouse gas emission for timber transoms are 6 times higher than in the concrete and composite transom [5]. However, an alternative material for the replacement of timber transoms shall be compatible with the existing structural system. Furthermore, it should also be able to be replaced without much effort in order to enhance resilience and maintainability [6-7]. Therefore, composite precast concrete retrofitted on the existing steel girder would be a good alternative.

It is interesting to find that train derailments keep presenting challenges to the railways system around the world. Indeed, not only can the derailments occur on turnouts and curved tracks, but they could also occur on a straight rail viaduct such as those due to broken bogie axles [8]. The aim of this study is to investigate the complex and unprecedented behaviour of composite transoms acting as track

slabs caused by train derailments. Failure modes of the rail transoms due to train derailments need to be well understood for public safety protection and fail-safe design principle of critical infrastructures. This outcome of this study will improve a performance-based design methodology for railway bridge transoms using steel-precast concrete composite members. Possible failure modes can be identified by previous failure investigations of railway bridges. Grayrigg train derailment in the UK [9] is a good example for progressive failure of railway structures triggered by derailments. Therefore, train derailment is a scenario, which cannot be ignored in designing structural components that enable a fail-safe railway system.

The steel-concrete composite transoms are being tested using full-scale specimens in the laboratory at Western Sydney University. However, in order to carry out experimental investigations, numerical analysis is required for a better insight into its dynamic behaviour so that test setup arrangement could be safely managed. Also, experiments are generally very expensive and time consuming. Therefore, this study is aimed at using numerical analysis to investigate the failure modes and behaviour of composite transoms caused by train derailment. Based on critical literature review, Brabie and Andersson [10] have investigated high speed derailments through various computer models. This simulation has been done on the wheel – sleeper impact when derailments occurred. They have further enhanced the model to simulate a post derailment scenario. Gu and Franklin [11] then created a model to analyse dynamic impact loading accurately. They considered the response of the railway bridge over the travelling speed of the train. Ju [12] studied non-linear behaviour of the wheel rail interaction. Effects of the profile of the track on derailment failure were later studied [13]. Fang and Zhang [14] developed a model to investigate the feasibility of using fiber concrete in transoms. In his study, a detailed parametric study was carried out by changing selected material properties of the fiber concrete to simulate different test models. However, all the above literatures did not considered the newly retrofitting precast steel-concrete composite slab into existing steel girders. The paper here is the first to look at the behaviour and failure modes of composite track slabs subjected to train derailment loads.

2. Structural track system, design load actions and derailment

Transoms are simply supported on stringers and the walk-way has been designed as a cantilever, as shown in Figure 1. The designed composite transoms are connected to the existing steel stringers using headed shear stud connectors. Existing rails then be fastened to the composite transoms using rail pads installed on steel baseplates. Actions of the design loads on transoms shall either be considered in their serviceability and ultimate limit states. LC1, LC2, LC5 and LC10, which will be described later, are considered as the most unfavorable load combinations or the set of worst case scenarios for design according to precedent research [1-2, 13]. The maximum static axle load acting on a transom during a train derailment has been taken as 20 tons, and its derailment impact can be calculated as per the guide lines established by the transport for New South Wales [2].

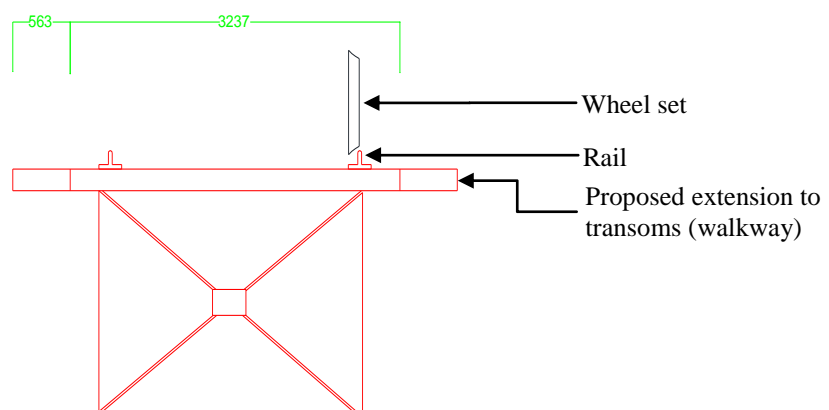

Figure 1: Structural system

3. Finite element model and its validation

Numerical model was developed using ABAQUS Explicit to simulate the impact of derailment loadings on the proposed steel-concrete composite panel [1-2]. For design purpose, the maximum influences on the composite transoms of single wheel derailment have been considered in the derailment model as is illustrated in Figure 2. Due to the nature of loading, which is applied on the stringer not being of importance, the model has been simplified using symmetry. The concrete slab and steel components were modelled using the eight-node linear hexahedral solid elements with reduced integration and hourglass control (C3D8R). Elements with reduced-integration have been adopted as they could reduce computing run time. These elements were incorporated in a reasonably fine mesh in order to improve the accuracy of these models. The mesh sizes were also verified by carrying out a sensitivity analysis to develop a convergence chart. The shear connectors were modelled using second order three-dimensional twenty-node quadratic brick elements with reduced integration (C3D20R). The connectors were modelled to represent the actual geometric size and shape within the limitations of the application. The reinforcing bars were modelled with two-node linear three-dimensional truss elements (T3D2). The track stiffness of 40 MPa (or rail displacement of 4.5mm specified by the rail authority) was used to validate the finite element model [2].

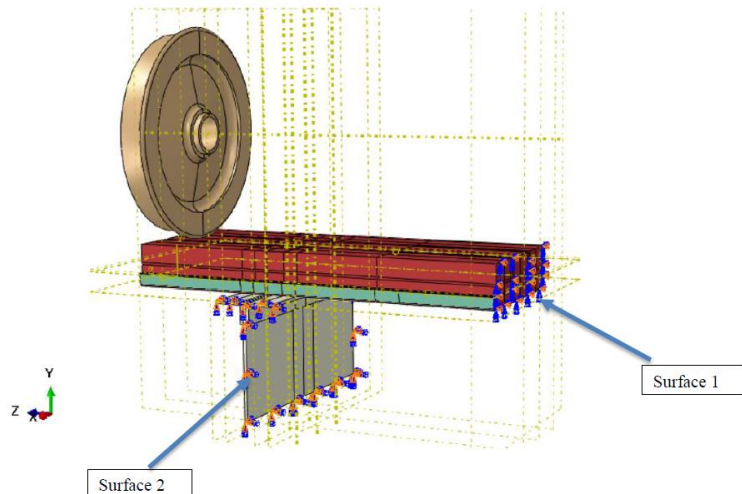

Figure 2: Finite element model

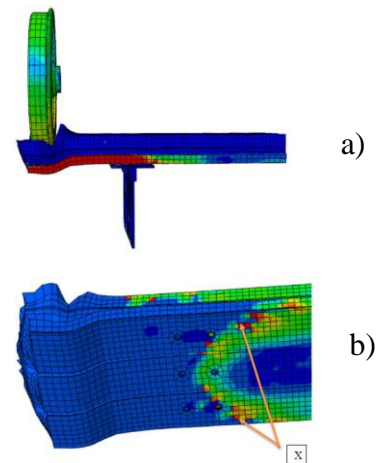

Figure 3: Finite element results

4. Results

The stress distribution in Figure 3(a) displays the resulting stress levels carried by the Bondek II at impact caused by derailment. The derailment relationship of the Bondek II is shown as stress versus time. From initial impact at time 0, the graph displays a linear curve up until about time 0.004, this is due to the combination of concrete and steel taking load. The maximum stress is reached at time 0.005 with a value of 550 MPa and fluctuates up until time 0.015. Beyond time 0.02 the stress level is reached and is maintained constant. Figure 3(b) displays the deformed model of the Bondek II caused at the impact once the wheel interacts with the panel. Figure 4 shows the parametric effects on the dynamic responses of the steel-composite composite track slab components.

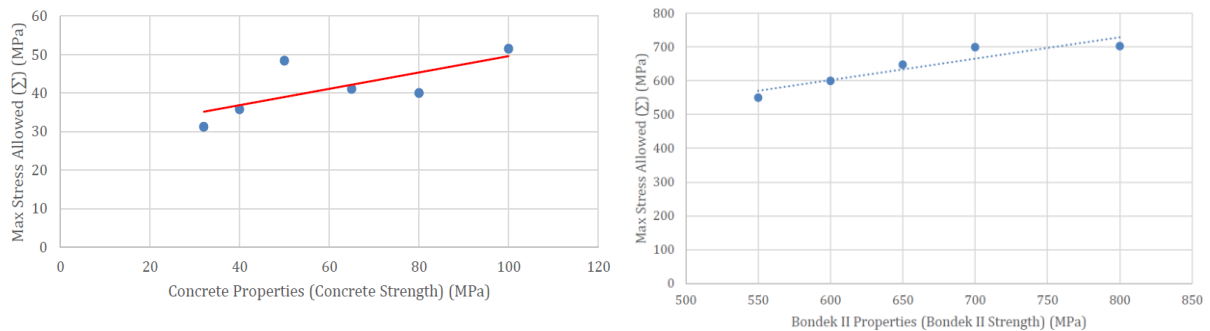

Figure 4: Parametric studies

5. Conclusions

Composite panels can be effectively used as a replacement of timber transoms in a railway bridge. In this study, the provisions given in the Australian standards was utilised for the composite steel-concrete transoms. A finite element model (FEM) was used to simulate the behavior of the composite transom under derailment loads. Impact loads were applied within a selected period of time. Allowable stresses in components of the composite transom could also be determined experimentally in the simulation. Stresses developed in various components were observed for deferent characteristic strength of the materials. The maximum allowable stress in concrete increased with increasing characteristic compressive strength of concrete. Defection control test simulation was done to find out the relationship between strength of Bondek sheet (yield strength) and the allowable stress. The allowable stress increased linearly until the yield strength of bondek sheet increased to 700MPa.

Acknowledgements

The first author wishes to gratefully acknowledge the Japan Society for Promotion of Science (JSPS) for his JSPS Invitation Research Fellowship (Long-term), Grant No L15701. The second author wishes to thank Western Sydney University for her Early Career Research Award. The authors are sincerely grateful to European Commission for the financial sponsorship of the H2020-RISE Project No. 691135 “RISEN: Rail Infrastructure Systems Engineering Network”.

References

- [1] Griffin, D., Mirza, O., Kwok, K., and Kaewunruen, S., ‘Composite slabs for railway construction and maintenance: a mechanistic review’, *The IES Journal Part A: Civil & Structural Engineering*, 7 (4), 243-262, 2014.
- [2] Griffin, D., Mirza, O., Kwok, K., and Kaewunruen, S., ‘Finite element modelling of modular precast composites for railway track support structure: A battle to save Sydney Harbour Bridge’, *Australian Journal of Structural Engineering*, 16 (2), 150-168, 2015.
- [3] Kaewunruen, S., Sussman, JM., and Einstein, H. H. ‘Strategic framework to achieve carbon-efficient construction and maintenance of railway infrastructure systems’. *Front. Environ. Sci.* 3:6. 2015, doi:10.3389/fenvs.2015.00006.
- [4] Kaewunruen S, Sussman JM and Matsumoto A. ‘Grand challenges in transportation and transit systems’. *Front. Built Environ.* 2:4. 2016, doi: 10.3389/fbuil.2016.00004
- [5] Krezo, S., Mirza, O., He, Y., Makim, P., and Kaewunruen, S. ‘Field investigation and parametric study of greenhouse gas emissions from railway plain-line renewals’. *Transp. Res. D Transp. Environ.* 42, 77–90, 2016. doi:10.1016/j.trd.2015.10.021
- [6] Kaewunruen, S., Griffin, DWP, Mirza, O, Kwok, K, ‘Resilience-based design of precast steel-concrete composites for railway track slabs’, *Proceedings of the 13th International Railway Engineering Conference, Edinburgh, 30 June – 1 July, 2015.*
- [7] Kaewunruen, S., Meesit, R., ‘Sensitivity of crumb rubber particle sizes on electrical resistance of rubberised concrete’, *Cogent Engineering*, 3(1), 2016. doi:10.1080/23311916.2015.1126937
- [8] Australian Transport Safety Bureau, ‘Derailment of Sydney Trains Passenger Train 602M’, ATSB Transport Safety Report Rail Occurrence Investigation RO-2014-001, Australian Capital Territory, Commonwealth of Australia, 2014.
- [9] The Guardian, ‘Grayrigg train crash’, [Access Online URL <http://www.theguardian.com/uk/grayrigg-train-crash>], 2016.
- [10] Brabie, D & Andersson, E, 'Dynamic simulation of derailments and its consequences', *Vehicle System Dynamics*, vol. 44, no. sup1, pp. 652-62. 2006.
- [11] Gu, G & Franklin, FJ, 'Application of the structural articulation method to dynamic impact loading of railway bridges – a case study', *Vehicle System Dynamics*, vol. 48, no. 10, pp. 1097-113, 2010.
- [12] Ju, SH, 'A simple finite element for nonlinear wheel/rail contact and separation simulations', *Journal of Vibration and Control*, vol. 20, no. 3, pp. 330-8. 2014.
- [13] Remennikov A.M. and Kaewunruen, S., ‘A review of loading conditions for railway track structures due to train and track vertical interaction’, *Structural Control and Health Monitoring*, 15 (2), 207-234. 2008.
- [14] Fang, Q and Zhang, J, 'Three-dimensional modelling of steel fiber reinforced concrete material under intense dynamic loading', *Construction and Building Materials*, vol. 44, no. 0, pp. 118-32. 2013.